

DROP BOTTOM SKIP

HINGED STIRRUP SAFETY

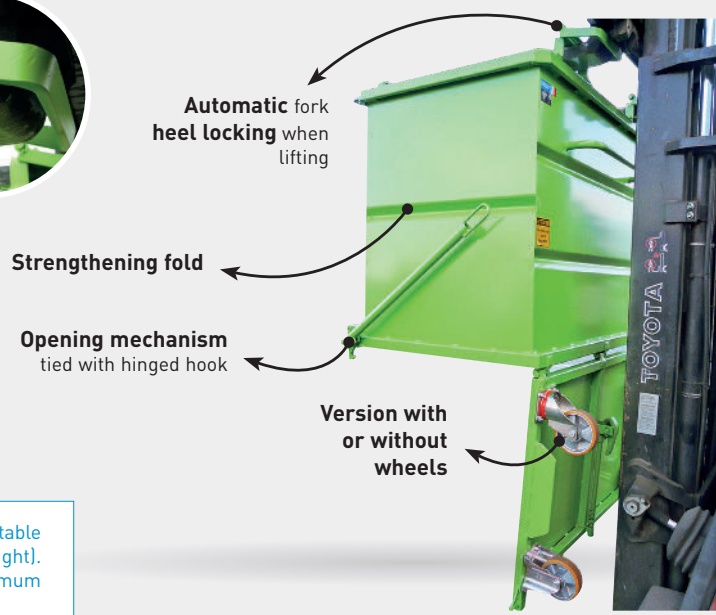

Full bottom emptying.
Best size/capacity ratio.
Automatically unlocks.

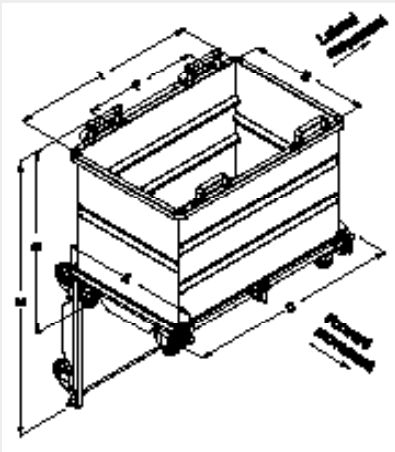

NOTE : Please ensure the forklift mast is at a suitable height (add value K from the table to the collection skip height). Check the section and the length of the forks - minimum length 1200mm (please contact us if lower length).

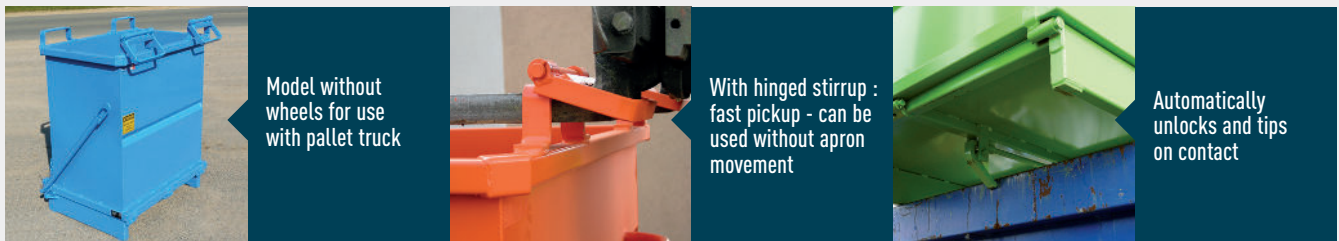

CHARACTERISTICS

- Capacity : 515 to 2075 litres
- Upper lifting lugs, aperture : 200 x 65 and spacing (F) 780 mm
- Sheet metal bin 2 mm rib, and 3 mm sheet metal bottom hardened by tubular frame
- Upper edge reinforced with 3-ply anti-cut rim
- Safety latch preventing any unintentional use
- Model without wheels for use with pallet truck
- Caster mounted models have 2 fixed and 2 pivoting castors and a handrail Forward movement except for 2075L which has lateral motion
- For customised or reinforced versions, please contact us
- Options : see P.40

Capacity litres	Load kg	Castors Ø	A	B	C	I	D	K	Weight kg	Painted ref.
515	1500	-	1000	800	1145	1000	920	1620	125	FAP05000
515	1200	125N	1005	800	1145	1000	970	1620	130	FAP05120
830	1500	-	1000	800	1395	1250	1110	1810	155	FAP08000
830	1200	125N	1005	800	1395	1250	1165	1810	160	FAP08120
1000	1500	-	1000	800	1345	1200	1320	2020	165	FAP10000
1000	1200	150P	1005	800	1345	1200	1420	2020	175	FAP10151
1400	1500	-	1100	900	1395	1250	1465	2265	185	FAP14000
1400	1200	150P	1105	900	1395	1250	1565	2265	195	FAP14151
2075	2000	-	1220	1000	1945	1800	1430	2350	255	FAP20000
2075	1800	160P	1225	1000	1980	1800	1530	2350	267	FAP20161

Castors : N = Nylon, P = alu/polyurethane - Dimensions in mm for basic model (for guidance only).