

# BIN TURNER

## UPPER GRIP

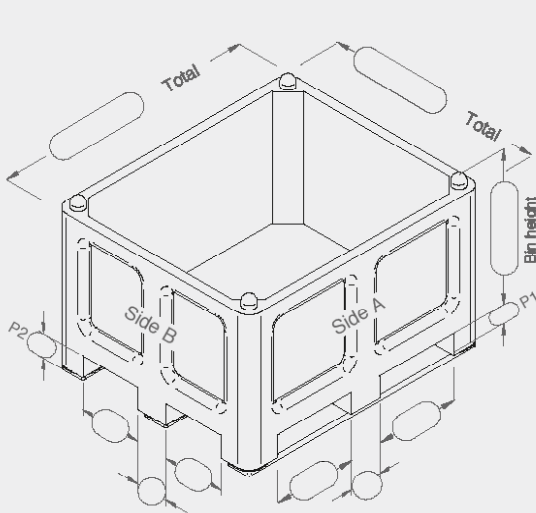

Suitable for all types of cases.  
Upper lifting using forklift truck.  
Load max 1500 kg depending on model.



Fork sleeves aperture ins. 170 x 70 mm Spacing 800 mm

Front emptying, manual or hydraulic tipping

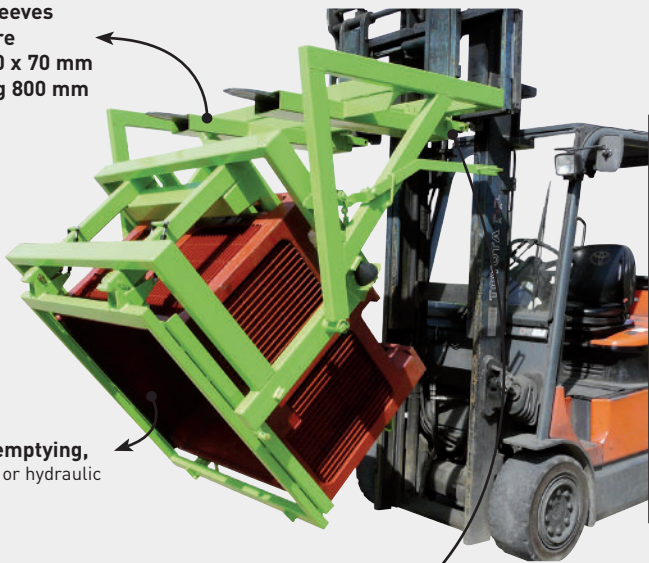

Fork heel safety locking

Table to download from our website (see RP page).

**INFORMATION REQUIRED FOR FEASIBILITY**

**Please indicate :** The dimensions of your case by filling in the above diagram. – forklift side indicated by A or B, bearing in mind there must be a minimum gap of 90mm (mark P1-P2). Cross section of your forks – Lifting height of forklift mast – Height of container.

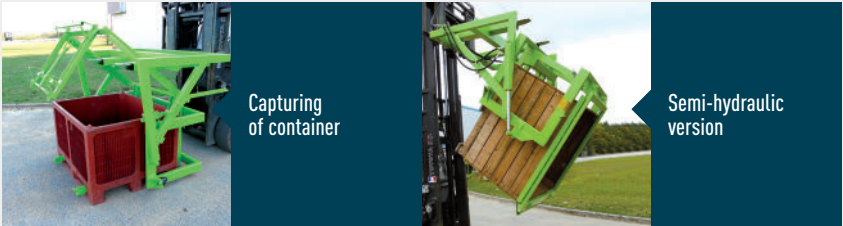

### CHARACTERISTICS

One of your bin is necessary to fit our RP.

**4 MODELS :**

**Manual version**  
Ref. RPP00000 for loads > à 500 kg

- Case stays inside the mobile frame mobile, fitted with 4 gas struts
- Frame closing and tipping controlled manually by lever

**Manual version**  
Ref. RPP10000 for loads < à 500 kg

- Case stays inside the mobile frame mobile, fitted with 4 gas struts
- Frame closing and tipping controlled manually by lever

**Semi-hydraulic version**  
Ref. RPP20000

- Load capacity 1000 kg
- Works exactly like the manual version with regards to the mobile frame.
- Hydraulic switch actuated by 2 double-action jacks (to connect to forklift).

**Fully hydraulic version**  
Ref. RPP30000

- Larger frame and hydraulic tipping (to connect to forklift)
- Customised production available - Contact us