



# BIG-BAG LOADER

## UPPER GRIP



Safe handling of Big-Bags.  
 Direct mounting on forks.  
 2 models with 1 or 2 hooks.  
 Approved by an inspection body.

**ATTENTION :** Prior to use, accessory + forklift acceptance procedures must be carried out by your authorised inspection body.

### Ref. CSP31000

Load 1T on 1 hook

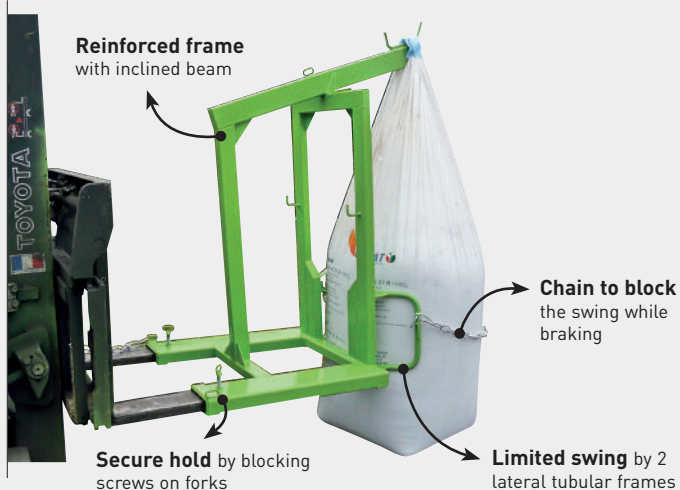
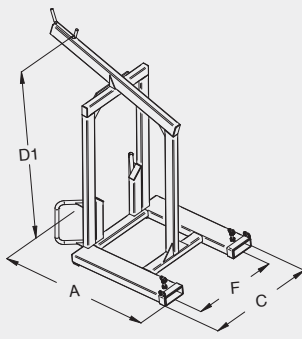

### Ref. CSP32000

Load 2T on 2 hooks

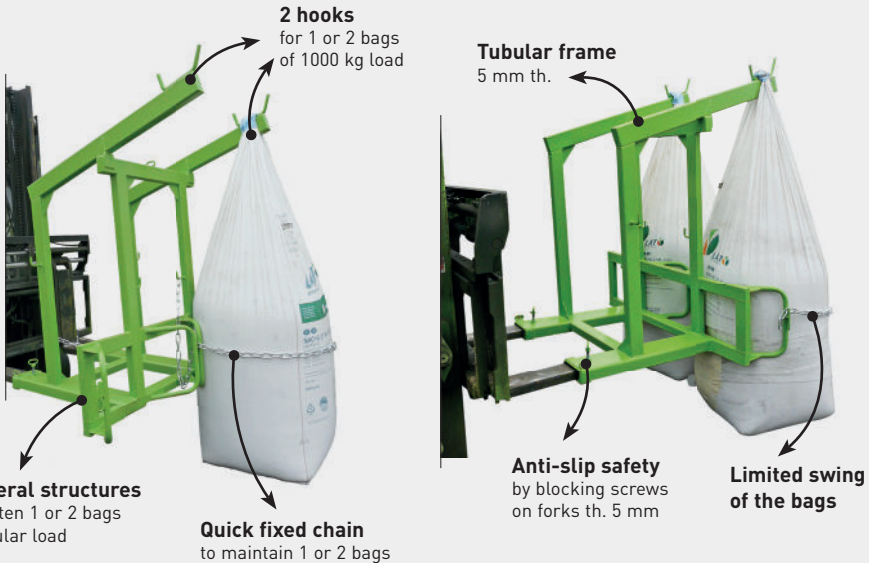
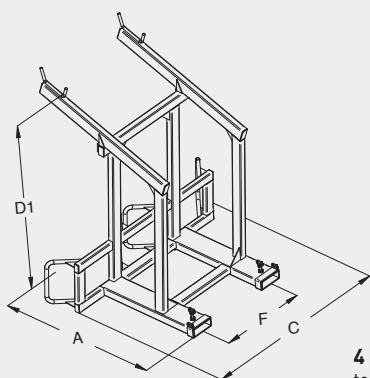

Load kg	A	C	D1	1200 fork CG	Fork sleeves ins.	F	Weight kg	Painted ref.
1T	1310	890	1570	605	165 x 55	700	102	CSP31000
2 x 1T	1310	1580	1570	626	165 x 55	700	137	CSP32000

Fork sleeves aperture and spacing [F] can be modified on request - Dimensions in mm for basic model (for guidance only).