

AUTO TIPPING SKIP FOR HEAVY PRODUCTS

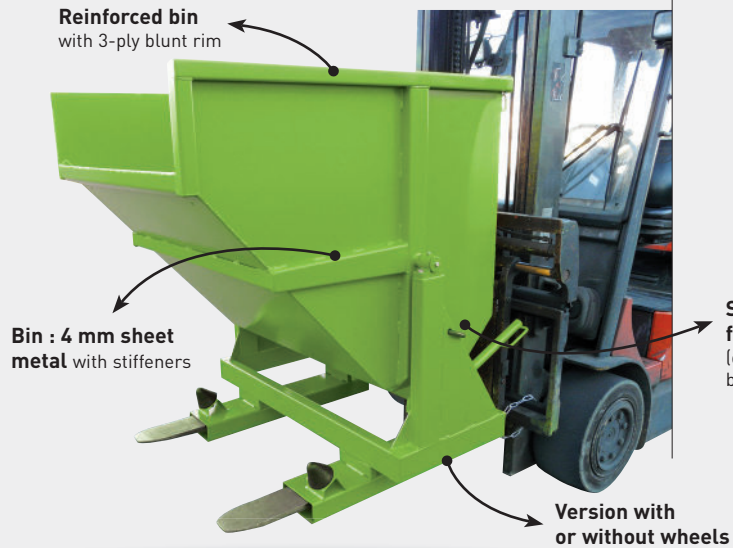

Intense use.
Ideal for scrap, waste from demolition, block hones...
Strong impact resistance.

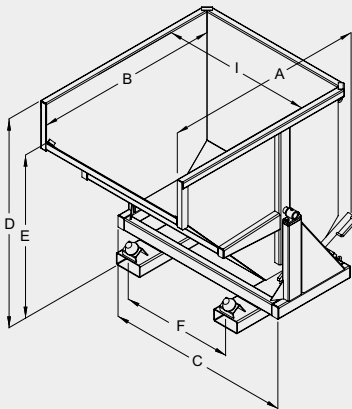

Bin stiffeners



Adjustable hinged handle



Deceleration cylinder

CHARACTERISTICS

- Capacity : 550 to 1150 litres
- Fork heel grip (optimizes offset)
- Bin : 4 mm sheet metal with stiffeners
- Rigid tubular chassis 100 x 50 x 4 mm
- Ø35 mm pivoting axis has bearings and grease nipples
- Rubber bumpers dampen end of tipping process
- Lever for manual tipping
- Fork sleeves aperture : 170 x 70 mm and spacing F can be modified on request
- Pedestal-mounted models can be used with pallet trucks (between fork sleeves)
- Castor-mounted models have 2 fixed + 2 pivoting castors and a handrail
- Safety chain included
- Options on request

Capacity litres	Load kg	Castors Ø	Movement	A	B	C	I	D	E	F	Weight kg	Painted ref.
80 series - Bin height 800 mm												
550	2500	-		1250	1200	1000	750	1250	1080	740	210	IRP05000
550	2400	160 F	Fwd.	1280	1200	1000	750	1295	1125	310	230	IRP05162
750	2500	-		1250	1200	1250	1000	1250	1080	740	235	IRP08000
750	2400	160 F	Fwd.	1280	1200	1250	1000	1295	1125	560	255	IRP08162
950	3000	-		1250	1200	1500	1250	1250	1080	900	285	IRP10000
950	2400	160 F	Lat.	1280	1200	1500	1250	1295	1125	810	305	IRP10162
1150	3000	-		1250	1200	1750	1500	1250	1080	900	320	IRP12000
1150	2400	160 F	Lat.	1280	1200	1750	1500	1295	1125	900	340	IRP12162

Lat. : Lateral movement - Fwd. : Forward movement - Dimensions in mm for basic model (for guidance only).