

# AUTOMATIC SKIP

## ESSENTIAL - LOAD 1000KG

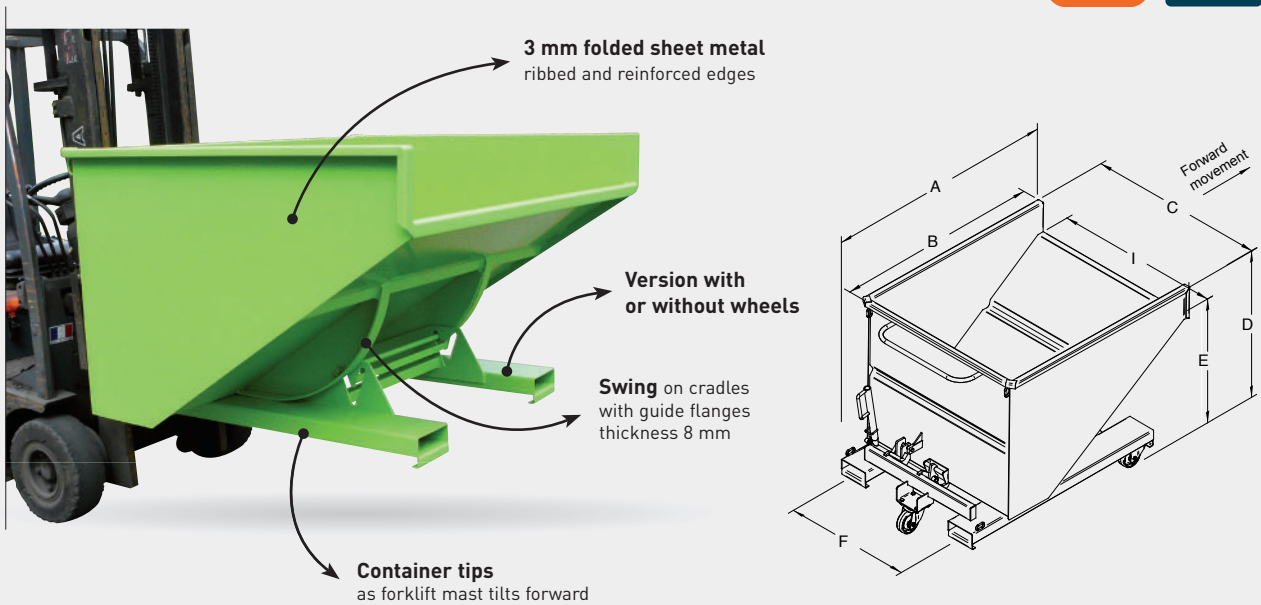

Tips and relocks by forklift mast tilts.  
Automatic release.



### CHARACTERISTICS

- Capacities from 510 to 1020 litres
- Automatically unlocks and tips on contact with container or manually using lever
- Fork sleeves aperture 165 x 55 mm and spacing (F) can be modified on request
- Pedestal mounted models can be used with pallet trucks between fork sleeves (except the 500 litres model)
- Castor-mounted models equipped with 2 fixed castors and 1 pivoting castor Ø125 nylon, with handrail
- Safety chain included
- Options on request

Capacity litres	Load kg	Castors Ø	A	B	C	I	D	E	F	Weight kg	Painted ref.
510	1000	-	1430	1230	835	750	940	745	540	160	XOP05000
510	1000	125	1430	1230	835	750	1065	870	540	165	XOP05123
680	1000	-	1430	1230	1085	1000	940	745	760	178	XOP07000
680	1000	125	1430	1230	1085	1000	1065	870	760	183	XOP07123
850	1000	-	1430	1230	1335	1250	940	745	760	192	XOP08000
850	1000	125	1430	1230	1335	1250	1065	870	760	197	XOP08123
1020	1000	-	1430	1230	1585	1500	940	745	760	205	XOP10000
1020	1000	125	1430	1230	1585	1500	1065	870	760	210	XOP10123

Dimensions in mm for basic model (for guidance only).