

BIN TURNER

BOTTOM GRIP

RC

Perfect for reduced lift height.
Bottom scoop by forks.
Calibrated for your bins.
Max. load 500 kg.



Video

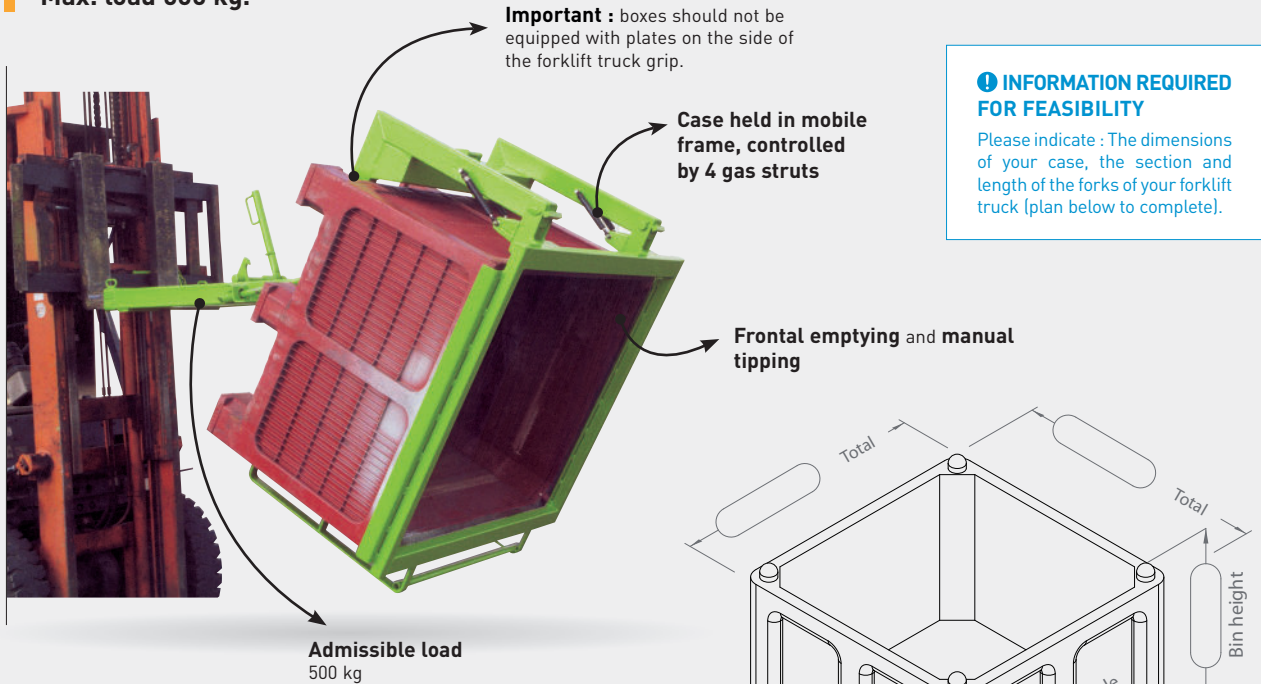

! INFORMATION REQUIRED FOR FEASIBILITY

Please indicate : The dimensions of your case, the section and length of the forks of your forklift truck (plan below to complete).

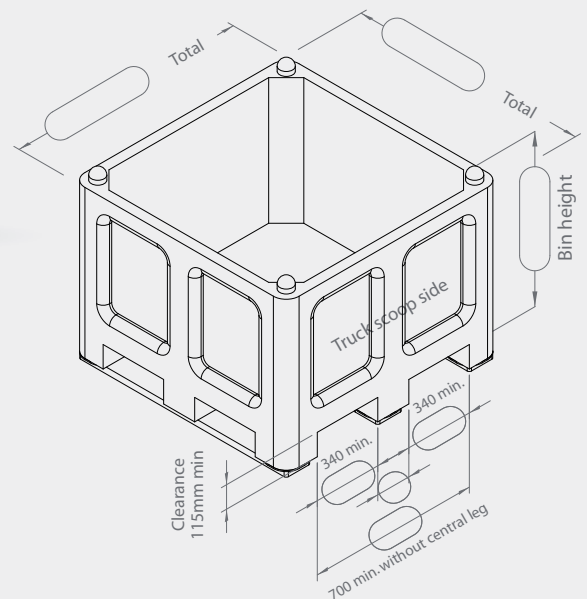

CHARACTERISTICS

Ref. RCP00000 – Weight 193 kg

- Manual control over closing the frame and tipping by lever
- Springs dampen the end of travel
- Fork sleeves aperture 170 x 70 and spacing 375 mm
- Safety locking mechanism on 1 fork heel

Table to download from our website (see RC page).
One of your bin is necessary to fit our RC.



Tipping angle 145°

Opened frame
for the container
recovery

4 gas cylinders