

OPEN TIPPING SKIP FOR HEAVY LOADS



Perfect for sheep metal frames and other flat products.

Automatic release.

Reinforced for heavy loads.

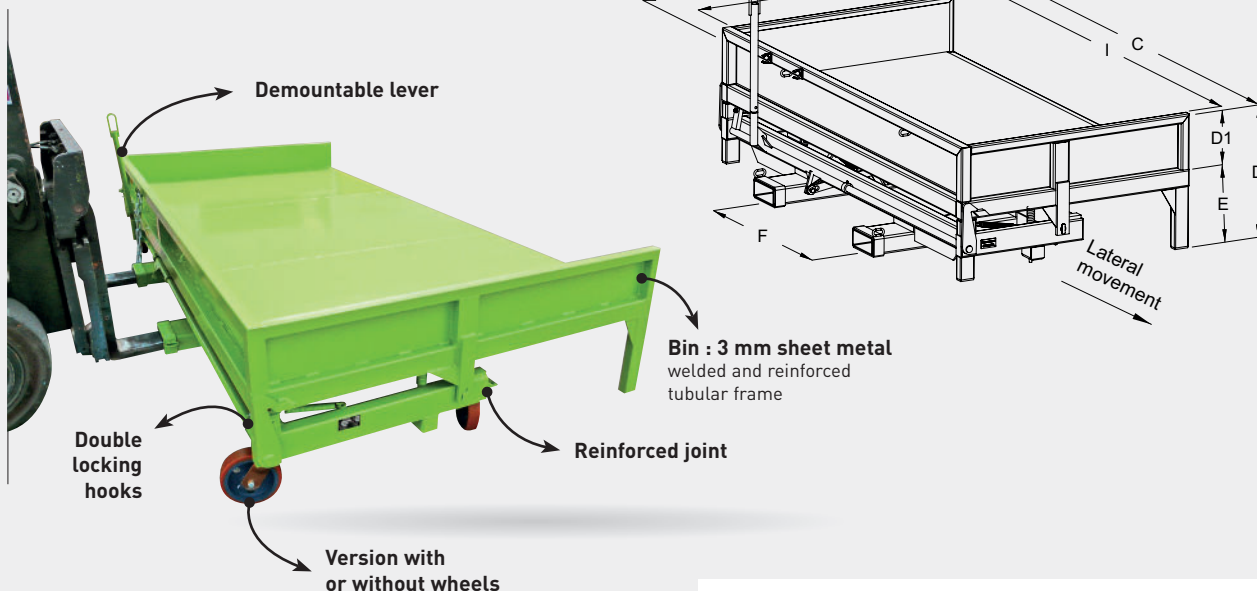

Models correspond to standard sheet metal sizes :
1000 x 2000, 1250 x 2500 and 1500 x 3000. (Other sizes and loads available on request)



Easy to empty



customised model with hinged door



Springs and pads dampen end of tipping process

CHARACTERISTICS

- Capacity : 580 to 990 dm³
- Automatically unlocks and tips on contact. Lever for manual tipping
- Fork sleeves can be modified on request : 5 mm sheet metal. Aperture 170 x 70 mm and spacing (F) : 900 mm
- Model without wheels can't be used with pallet truck
- Castor-mounted models (lateral movement) have 2 fixed + 2 pivoting cast iron/polyurethane castors on chassis
- Options on request

Capacity litres	Load kg	Castors Ø	A	B	C	I	D	D1	E	F	Fork CG	Weight kg	Painted ref.
580	2500	-	1295	1100	2230	2100	620	250	370	900	920	320	SQP06000
580	2250	160	1295	1100	2230	2100	715	250	465	900	920	340	SQP06162
880	2500	-	1535	1350	2730	2600	620	250	370	900	940	396	SQP09000
880	2250	160	1535	1350	2730	2600	715	250	465	900	940	417	SQP09162
990	3000	-	1785	1600	3230	3100	570	200	370	900	920	470	SQP10000
990	2800	200	1785	1600	3230	3100	710	200	510	900	920	507	SQP10202

Dimensions in mm for basic model (for guidance only).