

FILLING HOPPER AND BIG-BAG LIFT



**Filling and handling of the big-bag.
3 widths.
Permissible load 2 tonnes.
Approved by body of control.**

Painted or galvanized version

Choice of hopper
depending on the width
of the loading bucket



4 big-bag handles
for rapid unhooking

Mobile hopper to fit
on forklift truck forks

Automatic locking
on forks enabling
the bag to be
unhooked going
backwards



4 hooks
supporting the
suspended load

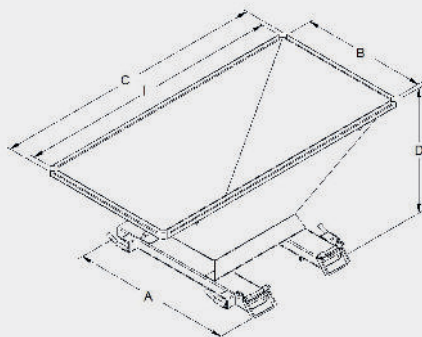

⚠ ATTENTION : Prior to use, accessory + forklift acceptance procedures must be carried out by your authorised inspection body.



Steep edges
improving the flow
of materials

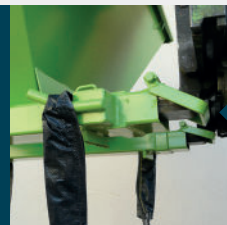

Automatic locking
by stirrups when
lifting

CHARACTERISTICS

- 3 mm steel panel hopper with reinforcement pleats
- 500 x 500 mm outlet channel
- Forks gripped in 5 mm thick sleeves, 170 x 55 int. passage, 680 mm between forks
- Distance between hooks 900 x 975 mm

Capacity litres	A	B	C	I	D	F	Weight kg	Painted ref.
830	1280	1000	1780	1700	870	680	170	TBP28000
830	1280	1000	2180	2100	910	680	176	TBP30000
1460	1280	1000	3080	3000	1140	680	233	TBP33000

Dimensions in mm for basic model (for guidance only).