

For safely handling and transporting joinery, plates, etc.
3 models.

Ref. CHP15000

Maximum load 3000 kg

1 central crane loading point ring



Forks inserted into fork sleeves aperture 170 x 70 mm

2 vertical side ramps for fitting slings

Ref. CHP25000

Maximum load 1500 kg

2 cranes loading rings with reinforcement brackets



Total depth 1700 mm

Support side rails and cross-members covered with interchangeable rubber section

Ref. CHP08000

Maximum load 800 kg

1 central crane loading ring with reinforcement brackets



Frame with vertical supports

2 support plates of 1200 mm total depth with anti-slip edge

CHARACTERISTICS

Ref. CHP15000

- Easel with inclined supports
- Support side rails and cross-members covered with interchangeable rubber section
- Special manufacturing on request

Ref. CHP25000

- Easel with inclined supports
- Forklift uses lower loops with 200 x 80 mm apert. and spacing (F) can be changed on request
- 2 vertical side ramps for fitting slings

Ref. CHP08000

- Forklift uses lower loops with 200 x 80 mm apert. and spacing (F) can be changed on request
- Cross-members covered with interchangeable rubber section
- 4 side loops for slings



Handling truck

- Reinforced frame on 4 wheels (2 fixed + 2 pivoting with brake Ø 160 alu/polyurethane or 200 iron/polyurethane for CHP16202) to move the loaded frame easily
- Handling truck Ref. CHP18161 for CHP08000
- Handling truck Ref. CHP16161 for CHP25000
- Handling truck Ref. CHP16202 for CHP15000

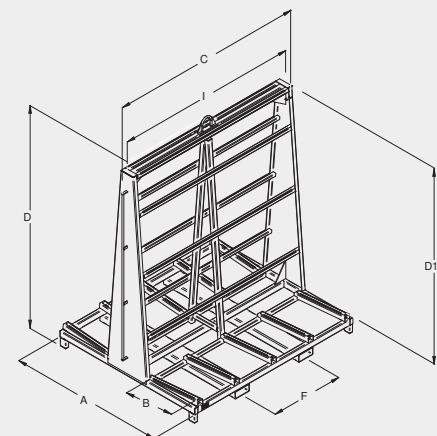

Load kg	A	B	C	I	D	D1	F	Fork sleeves ins.	Weight kg	Painted ref.
800	1200	560	2330	2210	2400	2100	800	200 x 80	175	CHP08000
1500	1700	600	2120	2000	2430	2130	800	200 x 80	215	CHP25000
3000	1700	580	2120	2000	2430	2130	800	170 x 70	305	CHP15000

Dimensions in mm for basic model (for guidance only).