

HUMANS EXPERTISE SOLUTIONS

A large, bright green metal skip or container, shown from a low angle, filling the right side of the page.

- SKIPS

- SHOVELS & BUCKETS

- HOPPERS

- ACCESSORIES

- CUSTOM-MADE

- OPTIONS

REACTIVITY

MADE IN FRANCE

ERGONOMICS

SELECTIVE SORTING / ENVIRONMENT

HANDLING

CONFIDENCE

QUALITY

SAFETY

MADE TO MEASURE

INNOVATION

ROBUSTNESS

ADVICE

KNOWHOW

Confidence increases as time passes :

Airbus, Arcelor, Areva, Beneteau, Bonduelle, Carbone Savoie, Cointreau, Fenwick, Gedimat, La Plateforme du Bâtiment, Lafarge, Lapeyre, Manitou, Michelin, Nestlé, Point P, RATP, Saint-Gobain, Sita, SNCF, Suez, Tefal, Terrena, Valeo, Véolia, ...

A FAMILY WITH GREAT IDEAS IN THE SERVICE OF BUSINESSES

1938 : Louis Goubard, visionary businessman, founds in Cheviré Le Rouge(49) his company for manufacturing agricultural equipment, first in wood and then in steel (wagons, tumbrels, barrels, tractor trailers etc).



1968 : Pascal Goubard, son of the founder, joins the company with his wife Monique. With his eye for innovation, he designs the first tipping trailers for refuse, including a version, capable of being held by a forklift, for use in the wood industry.



1974 : Goubard plays an active part in the Paris International Handling Equipment Fair. The «dare to be different» nature of its products is noted, and marketing of Goubard trailers extends nationwide. The trailers adopt their green colour as a sign of recognition of the make.

1992 : The company moves to a new site at Seiches-sur-le-Loir (49) and steps up its industrial production (total of 10 employees).

1993 : Early death of Pascal Goubard Gérard Toulhier, brother of Monique Goubard, takes over and becomes the manager.

2005 : Already a leader in France, Goubard branches out to international level, extending into Europe.

2018 : Goubard now employs 59 people, produces over 6,000 items a year and offers the widest range available on the market, with 70 different skips, hoppers, buckets, shovels plus lifting and handling accessories.



ALWAYS OFFER THE BEST SOLUTIONS

Ever since it was founded, Goubard has been distinguished by its readiness to offer each client the solutions best adapted to their needs.

Our in-depth knowledge, our sense of innovation and our capacity for made-to-measure manufacture help us meet all your expectations.



THE WIDEST CHOICE ON THE MARKET

As France's leading manufacturer of skips, Goubard can provide over 600 references, standard or made to measure, with 70 different skips, hoppers, buckets, shovels and spades, plus lifting and handling accessories.

This is what makes the Goubard products' reputation :

- **Quality and reliability**
- **Robustness and safety**
- **Reactive and made to measure**
- **100% French design and manufacture, in our workshops at Seiches-sur-le-Loir**
- **Compliance with European standards**
- **Innovation and exclusive patents**



RESEARCH AND DEVELOPMENT

A five-strong team in our study office is continually working to improve our products, by always looking out for changes in your needs. Goubard thus endeavours every day to design and develop innovative technical responses that meet the specific demands of your area of work in every way.

Goubard cares about your experience as a user.

Can't find a standard model that suits you? Always ready to listen to you, we will provide you with made-to-measure manufactured items by developing optimised solutions for your each and every need.



OUR COMMITMENT

In a constructive and transparent relationship with its clients, Goubard will accompany you on a daily basis, in a spirit of long-term partnership based on fundamental values and assets such as :

- High-quality work
- Desire for client satisfaction
- A sense of innovation
- Human values
- Flexibility of adaptation
- Ongoing client assistance

THE TEST A UNIQUELY GOUBARD OFFER

To ensure that you are sure of your choice, Goubard offers you a chance to test before you commit.

95% of clients who test our products later buy them!

To find out about test methods and test an item of Goubard equipment, call :

+33 2 41 76 36 52



www.goubard.fr

Go on line to find all our products and options, more photos, and demonstration videos... All the information needed for making the right choice!



MEN AND WOMEN BY YOUR SIDE

Z.A. de Suzerolle nord
CS 80035
49140 Seiches-sur-le-Loir, France

T. +33 (0)2 41 76 36 52
F. +33 (0)2 41 76 63 33
export@goubard.fr
www.goubard.fr

**Your contacts are always ready
to listen to you by phone,
Monday to Friday.**



G Goubard
SEICHES-SUR-LE-LOIR

A TEAM AT THE HEART OF YOUR PROJECTS



Depending on where you are located, contact directly

EXPORTS

Martine FAUQUEREAU

RESEARCH & DEVELOPMENT, MADE TO MEASURE PRODUCTS

Jérémie BOURDILLON
Technical Manager

BUSINESS SECTOR

Dépt. EVEN-NUMBERED*

Martine FAUQUEREAU, Sector Manager
Amélie ZAMPARO, Business Manager

Dépt. IODD-NUMBERED*

Nathalie CHAUVELLIER, Sector Manager
Sandrine JUMEAU, Business Manager

* Département No

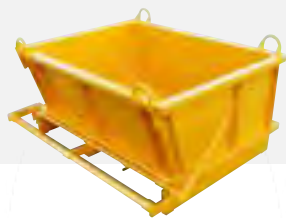

OUR SOLUTIONS



SOLUTIONS WITH PEOPLE IN MIND...

The safety of the operative and their working conditions have always been at the core of the design of our products.

Several innovations and patents have strengthened active and passive safety :

- Automatic unlocking of tilting by switch
- Fork locking
- Slide limiter
- Safety latch

All our products are compliant with the health and safety requirements of European Directive 2006/42/EC of 17 May 2006.



...AND THE ENVIRONMENT

Fully involved in your environmental procedures, **through our products, we help optimize the collection and sorting of waste in your company.**

With a genuine understanding of the realities of your business, we integrate your industrial processes and the regulatory constraints of your equipment to provide you with effective and sustainable solutions, while reconciling cost savings, productivity and technical expertise.



CONSTANT INNOVATION

Our technical teams design and develop new products to anticipate the expectations of the various markets and standards. They are highly committed to research and development in order to design and manufacture solutions that you can trust. With our historical and local know-how, we are cultivating the « Made in France » mentality.



CUSTOMISED SOLUTIONS FOR ALL REQUIREMENTS

Build the product that best meets your requirements in complete freedom :

- Dozens of options adapted to all requirements
- Painted, galvanized or stainless steel finish
- Choice of colour
- Option of special tailor-made products

For information on all the details and terms and conditions for made-to-measure ordering, refer to page 107 of the catalogue.

SOLUTIONS FOR ALL HANDLING OPERATIONS

Our products are equipped with various type of grips depending on your handling equipment :

- Front forklift fork grips, with rotating head, stacker
- Crane / Spreader / Slings
- Clamp Truck
- Other grippers : grappling hook / telescopic...

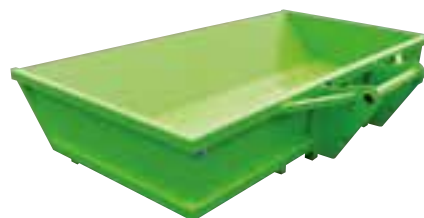

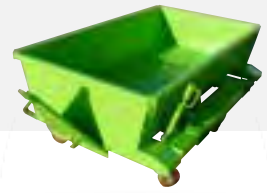

PRACTICAL GUIDE

UNDERSTANDING OUR TECHNICAL DIAGRAMS

Glossary :

- A : overall depth
- B : interior depth
- C : interior depth
- I : interior width
- D : overall height
- D¹ : interior height
- E : maximum loading height
- K : overall height (when emptying)
- F : fork sleeves spacing

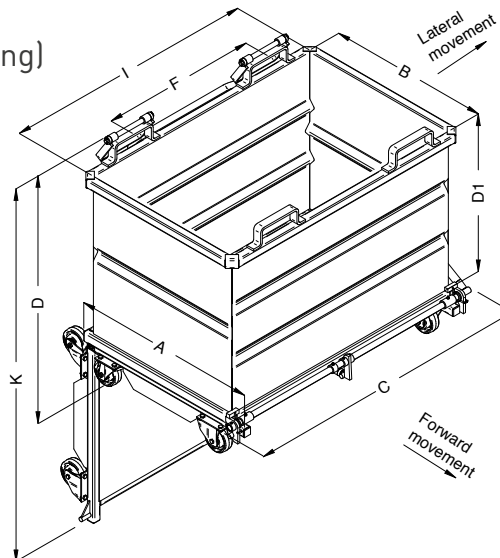
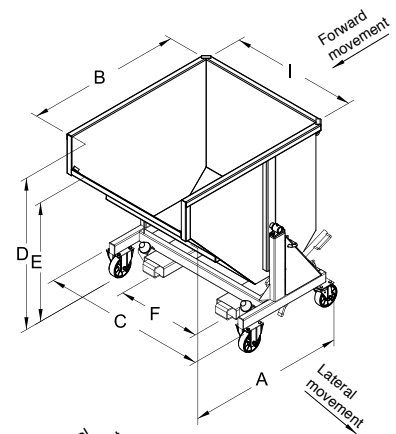



SHOVELS & BUCKETS



SHOVELS & BUCKETS

GVL	Hydraulic bulk bucket load 1.5 to 3T	63
GVT	Hydraulic bulk bucket load 1 to 1.5T	62
PCH	Loading shovel hydraulic tilting	61
PCM	Loading shovel mechanical tilting	60



LOADING SHOVEL

MECHANICAL TILTING



For use with forklift.
Manual tipping.
For loading bulk products from ground level.

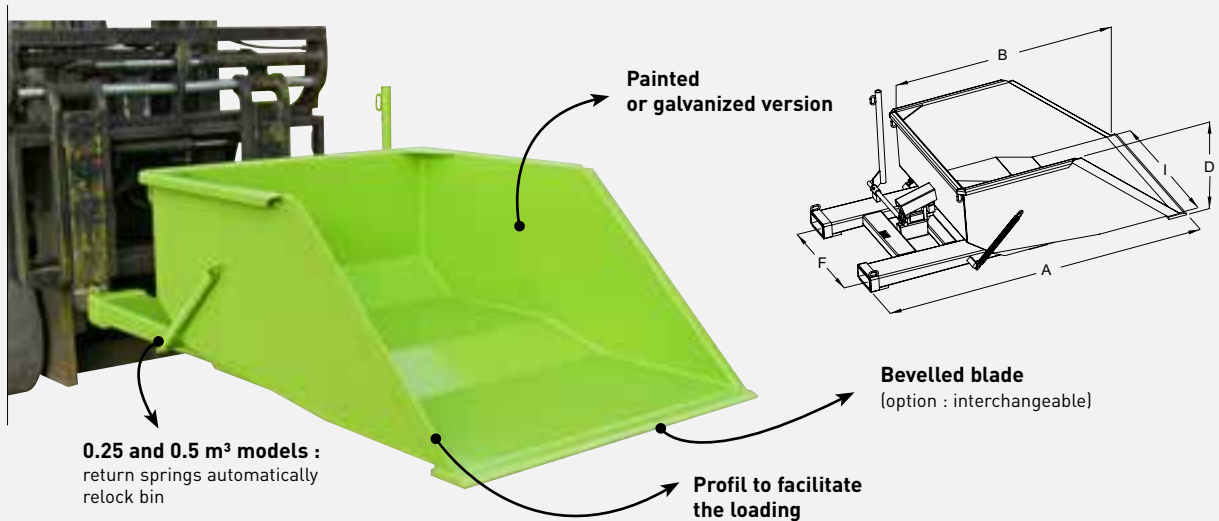

CHARACTERISTICS

- Capacity 0.25 to 2.5 m³
- Flat bottom : 5 mm sheet metal (0.25 m³ to 0.8 m³ models) or 6 mm sheet metal (1.5 m³ to 4 m³ models)
- Bevelled blade, 400 HB, 15 mm sheet metal
- Welded band reinforces fork sleeves entry points
- Tipping angle : 120°
- Metal casing protects locking spring and hook
- Safety chain included

Capacity m ³	Load kg	A	B	I	D	F	Fork sleeves ins.	Fork CDG	Weight kg	Painted ref.
0.25	1000	1720	1100	750	490	470	170 x 65	1060	168	PMP07502
0.5	1500	1940	1300	1000	560	700	170 x 65	1060	220	PMP10005
0.8	2000	1950	1300	1300	760	700	170 x 65	1060	270	PMP13010
1.5	2000	1950	1500	1500	800	900	170 x 65	1110	353	PMP15015
2	2500	1855	1500	2150	800	900	170 x 70	1050	445	PMP20020
2.5	2500	1855	1500	2150	1010	900	170 x 70	1030	470	PMP20025

Dimensions in mm for basic model (for guidance only).

LOADING SHOVEL

HYDRAULIC TILTING



- For use with forklift.
- Hydraulic tipping.
- Comfort of use.
- For loading bulk products from ground level.

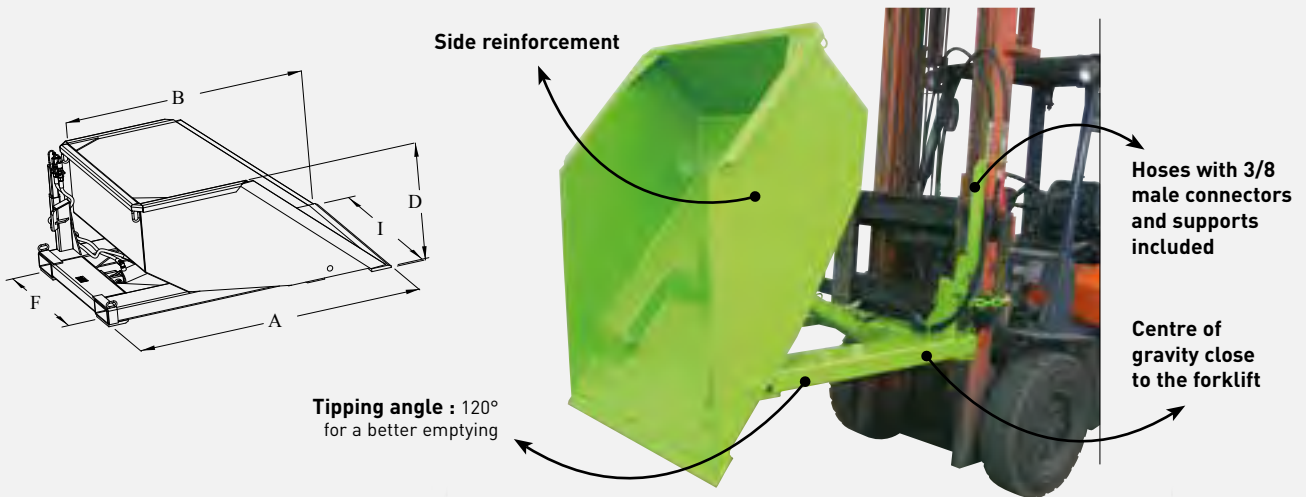

CHARACTERISTICS

- Capacity : 0.25 m³ to 4 m³
- Flat bottom : 5 and 6 mm following capacities
- Beveled blade, 400 HB, 15 mm sheet metal
- Hydraulic dumping : connect a double-acting cylinder to forklift (side shift carriage) 4 m³ model has 2 cylinders
- Hoses with 3/8 male connectors and supports included

Capacity m ³	Load kg	A	B	I	D	F	Fork sleeves ins.	Fork CDG	Weight kg	Painted ref.
0.25	1000	1590	1270	750	450	535	170 x 70	850	210	PHP07502
0.5	1500	1590	1300	1000	650	785	170 x 70	700	256	PHP10005
0.8	2000	1620	1300	1300	740	700	170 x 70	720	309	PHP13010
1.5	2000	1790	1500	1500	820	900	170 x 70	780	395	PHP15015
2	2500	1790	1500	2150	820	900	170 x 70	800	457	PHP20020
2.5	3000	1790	1500	2150	1020	900	170 x 70	780	488	PHP20025
3	3000	1880	1700	2150	1070	900	170 x 70	750	584	PHP20030
4	3500	1880	1700	2500	1220	1000	170 x 70	700	704	PHP25040

Dimensions in mm for basic model (for guidance only).

HYDRAULIC BULK BUCKET

LOAD 1 TO 1.5 T.



For use with forklift.

For loading products (grain, chips, fertilisers, sand, etc.) from ground level.



CHARACTERISTICS

- Capacity : 0.5 to 1.1 m³
- 5 mm heavy-duty scoop
- Articulation joints have bearings and grease nipples
- Hydraulic connection with 2 double-acting cylinders (hoses with 3/8 male connectors)
- Safety chain included
- Option interchangeable blade

Capacity m ³	Load kg	Overall depth	Bin depth	Scoop width	Centre interior height	Center to center forks	Fork sleeves ins.	1200 fork CDG	Weight kg	Painted ref.
0.5	1000	1555	1030	1250	550	800	170 x 70	870	320	GNP05002
0.8	1500	1620	1230	1500	700	800	170 x 70	870	377	GNP08002
1	1500	1620	1230	1750	700	900	170 x 70	870	407	GNP10002
1.1	1500	1620	1230	2000	700	900	170 x 70	870	440	GNP11002

Dimensions in mm for basic model (for guidance only).

HYDRAULIC BULK BUCKET

LOAD 1.5 TO 3 T.



- Direct lift on forks.
- Loading close to apron.
- U-shaped scoop - complete emptying.



CHARACTERISTICS

- Capacity : 0.25 to 3 m³
- 5 mm or 6 mm heavy-duty scoop
- Articulation joints have bearings and grease nipples
- Hydraulic dumping : connects 2 double-acting cylinders to forklift (side shift carriage)
- Hoses with 3/8 male connectors and supports included
- Option interchangeable blade

Capacity m ³	Load kg	Overall depth	Bin depth	Scoop width	Centre interior height	Center to center forks	Fork sleeves ins.	1200 fork CDG	Weight kg	Painted ref.
0.25	1000	1500	770	1000	425	460	170 X 70	880	260	GLP02503
0.5	1500	1520	1000	1250	500	500	170 X 70	880	385	GLP05003
1.1	2000	1450	1260	1500	730	800	170 X 70	790	437	GLP11003
1.3	2000	1450	1260	1750	730	900	170 X 70	790	464	GLP13003
1.5	2000	1450	1260	2000	730	900	170 X 70	795	492	GLP15003
2	2500	1700	1590	2000	860	900	170 X 70	810	648	GLP20004
2.4	2500	1785	1700	2000	990	900	170 X 70	810	702	GLP24004
3	3000	1785	1700	2500	990	1000	170 X 70	815	783	GLP30004

Dimensions in mm for basic model (for guidance only).

A close-up, grayscale photograph of a metal hinge mechanism on a door or panel. The hinge is a heavy-duty, industrial-style design with a cylindrical rod and a bracket. The background is a textured, metallic surface. The word "OPTIONS" is overlaid in white, bold, sans-serif font, with a horizontal line underneath it.

OPTIONS

OPTIONS

FINISH/BLOCKING/RELEASE

Finishing choice :

Stainless steel, galvanized version or customised paintwork



Blocking on forks (BFP)



Automatic release (DAP) :

by pressure, by contact, by drawbar



OPTIONS

LIDS

Sliding lid (CLP)
plastic strips or metal version



Dead-light (OPP)



Hinged two parts lid (COP)



Folding lid on BR



Custom removable lid (COS)

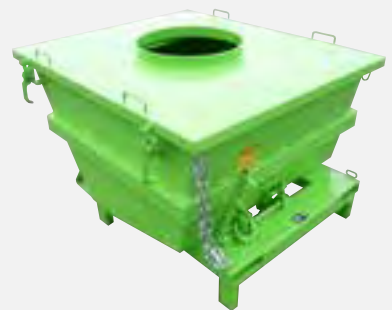

Fixed lid with virole (CVP)



Articulated lid with 1 ferrule (VIP)



Special cover
Lockable, opening with gas compass



OPTIONS

SPECIAL SLEEVES

For stacker



Clamps hold on tipping bin



Clamps hold on drop bottom skip



3 points for tractor



Fork sleeves on 3 sides (PTP)



Opening limiter (LOP)



Guide flanges (FLP)



Locked bin tilted (BBP)



OPTIONS OTHERS

Grille and drain tap
(GRP)



Leakproof door
with foam seal (FEP)



Adhesive letters
(MAP)



Trailer drawbar
(TRP10000)

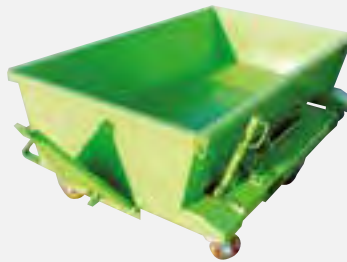

Deceleration cylinder
for end of tipping process (VRP)



Hydraulic tipping
1 or 2 cylinders (BHP)



OPTIONS OTHERS

4 lifting lugs
(BAP)



Security by screw



Special leakproof inspection window
(in steel or plexiglass on request)



Tarpaulin or netting
(FBP)



Cross fork sleeves
on FAP/CAP models (FVP)



Lid
with aluminum roller shutter



Customized leak-proof lid
with ferrule on tipping skip



**OTHER OPTIONS
CONSULT US**

CUSTOM MADE PRODUCTS



CUSTOM MADE PRODUCTS



IMAGINE, INNOVATE, CREATE, GAIN YOUR TRUST...

With **recognized know-how**, an ability to listen and professional expertise, we add to our wide range of standard products with tailor-made products to become your ideal partner and offer you :

- **Unique expertise in the analysis of your requirements**
- **Personalised advice**
- **Solutions to each of your issues**
- **A proactive service**
- **Guaranteed quality, reliability and safety**

Our design office works every day to invent and develop products to provide you with solutions adapted to your requirements and the regulations (EC).

The contract manager is your contact with all the company's services. They guide you through the development of your project and answer all of your questions.

Talk to us and benefit from our experience.

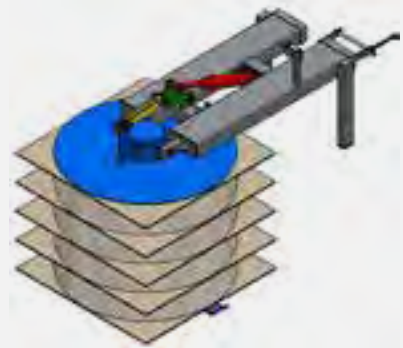

A tailor-made product designed to meet all your requirements !

CUSTOM MADE PRODUCTS

Multi-compartment skip

Tilting or opening bottom



Wire mesh version



Adaptation with hinged tipping



Bin with opercule or special glass hatch



CUSTOM MADE PRODUCTS

Adaptation fork sleeves

For lift truck with clamps



Hydraulic nipper

nipper



Tilting frame

For making wood faggots



BR-C skip

with command of opening lid with pedal



Special jib stacker grip

for storage platform



Hydraulic tilting

specific



Autonomous tilting device

12 volts - for plastic bin

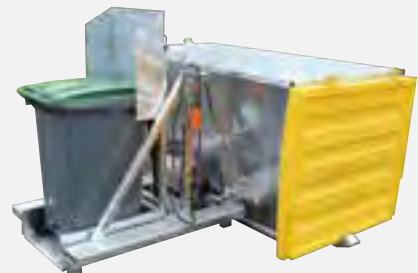

CUSTOM MADE PRODUCTS

Mobile ramp
special QL



Mounting on specific wheels
For use with or without



Truck
for fire equipment



Truck
Handling



Open-bottom skip
with special lid



CUSTOM MADE PRODUCTS

Special skip
for telescopic truck

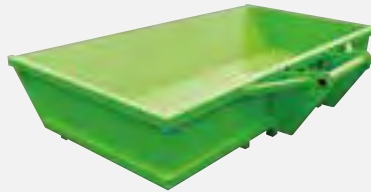

Grab point



Coupling with drawbar



Open sides
for long products

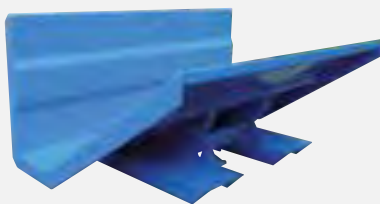
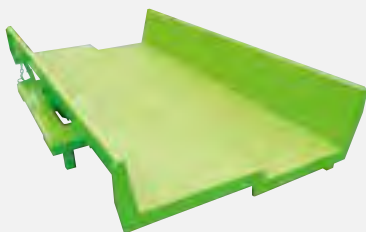

Skip
with double-axle steering



CUSTOM MADE PRODUCTS

Reinforced skips
Steelworks / foundry / aspiration



Hydraulic tilting
on tipping skip



Skip
for machine environment



Sloped bottom skip
special

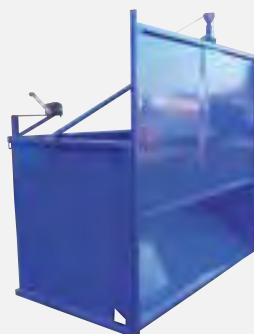
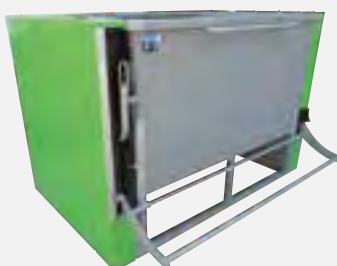
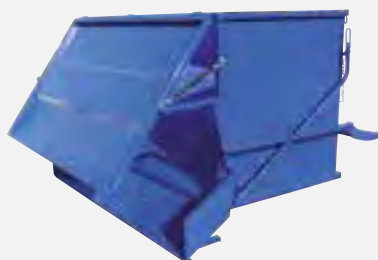

TELL US WHAT YOU NEED AND WE'LL MAKE THE SKIP TO FIT!



FOR A FREE ESTIMATE, PLEASE FILL IN THE FORM BELOW AND RETURN IT TO US.

Company :

Contact/Name :

Address :

Post code : City :

Tel. : Fax : E-mail :

Sphere of activity :

YOUR TECHNICAL REQUIREMENTS

Type of products handled :

Estimated load :

FINISH : Painted galvanized Stainless steel Food-safe paint Leak proof bin

TYPE : Pedestal-mounted model Castor-mounted model 2 fixed + 2 pivoting 4 pivoting
Forward movement Lateral movement

For use with : Forklift Stacker

Tipping system : Manual Hydraulic

QUANTITY :

DESIRED OPTIONS AND/OR COMMENTS :

DIMENSIONS REQUIRED

A (overall depth) :

or

B (interior depth) :

C (overall width) :

or

I (interior width)) :

D (overall height) :

F (fork sleeves spacing) :

Dimensions of your forks : X

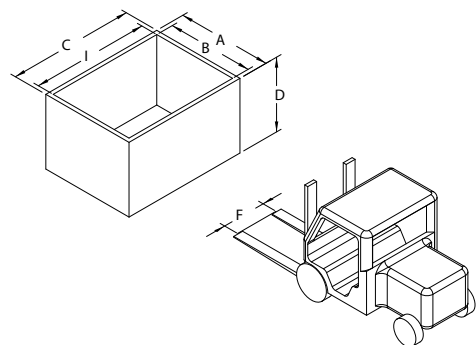

INFORMATION REQUIRED FOR A SUITABLE SOLUTION

INFORMATION ON YOUR NEED

- Choice of the equipment : skip, shovel, hopper, accessorie...
- Nature of products / handled waste
- Density or estimated load
- Capacity (in liters), desired dimensions
- Version on base / on wheels
- Finish : painted / galva / stainless steel...
- Quantity
- Options
- Other constraints to respect



INFORMATION ON THE HANDLING

- Prehension by : forklift truck, stacking truck, crane....
- Place of emptying
- Diverse constraints
- Section and spacing forks
- Load, lifting height of the forklitf truck

Well expressed choices facilitate selection !

ADD COLOUR YOUR WORKING ENVIRONMENT !

Our products are coated with a green polyurethane paint. As standard, we also offer the range of RAL colours below. Other RAL colours are available as an option so that our products can integrate seamlessly into your environment.



GREEN
Standard



YELLOW RAL
1003



YELLOW RAL
1028



ORANGE RAL
2004



RED RAL
3000



BLUE RAL
5015



GREEN RAL
6029



GREY RAL
7036



BROWN RAL
8004



BLACK RAL
9005



WHITE RAL
9010





Goubard

Z.A. de Suzerolle nord

CS 80035

49140 Seiches-sur-le-Loir, France

T. +33 (0)2 41 76 36 52

F. +33 (0)2 41 76 63 33

export@goubard.fr

www.goubard.fr