

HUMANS EXPERTISE SOLUTIONS



● SKIPS

● SHOVELS & BUCKETS

● HOPPERS

● ACCESSORIES

● CUSTOM-MADE

● OPTIONS

REACTIVITY

MADE IN FRANCE

ERGONOMICS

SELECTIVE SORTING / ENVIRONMENT

HANDLING

CONFIDENCE

QUALITY

SAFETY

MADE TO MEASURE

INNOVATION

ROBUSTNESS

ADVICE

KNOWHOW

Confidence increases as time passes :

Airbus, Arcelor, Areva, Beneteau, Bonduelle, Carbone Savoie, Cointreau, Fenwick, Gedimat, La Plateforme du Bâtiment, Lafarge, Lapeyre, Manitou, Michelin, Nestlé, Point P, RATP, Saint-Gobain, Sita, SNCF, Suez, Tefal, Terrena, Valeo, Véolia, ...

A FAMILY WITH GREAT IDEAS IN THE SERVICE OF BUSINESSES

1938 : Louis Goubard, visionary businessman, founds in Cheviré Le Rouge(49) his company for manufacturing agricultural equipment, first in wood and then in steel (wagons, tumbrels, barrels, tractor trailers etc).



1968 : Pascal Goubard, son of the founder, joins the company with his wife Monique. With his eye for innovation, he designs the first tipping trailers for refuse, including a version, capable of being held by a forklift, for use in the wood industry.



1974 : Goubard plays an active part in the Paris International Handling Equipment Fair. The «dare to be different» nature of its products is noted, and marketing of Goubard trailers extends nationwide. The trailers adopt their green colour as a sign of recognition of the make.

1992 : The company moves to a new site at Seiches-sur-le-Loir (49) and steps up its industrial production (total of 10 employees).

1993 : Early death of Pascal Goubard Gérard Toulrier, brother of Monique Goubard, takes over and becomes the manager.

2005 : Already a leader in France, Goubard branches out to international level, extending into Europe.

2018 : Goubard now employs 59 people, produces over 6,000 items a year and offers the widest range available on the market, with 70 different skips, hoppers, buckets, shovels plus lifting and handling accessories.



ALWAYS OFFER THE BEST SOLUTIONS

Ever since it was founded, Goubard has been distinguished by its readiness to offer each client the solutions best adapted to their needs.

Our in-depth knowledge, our sense of innovation and our capacity for made-to-measure manufacture help us meet all your expectations.



THE WIDEST CHOICE ON THE MARKET

As France's leading manufacturer of skips, Goubard can provide over 600 references, standard or made to measure, with 70 different skips, hoppers, buckets, shovels and spades, plus lifting and handling accessories.

This is what makes the Goubard products' reputation :

- **Quality and reliability**
- **Robustness and safety**
- **Reactive and made to measure**
- **100% French design and manufacture, in our workshops at Seiches-sur-le-Loir**
- **Compliance with European standards**
- **Innovation and exclusive patents**

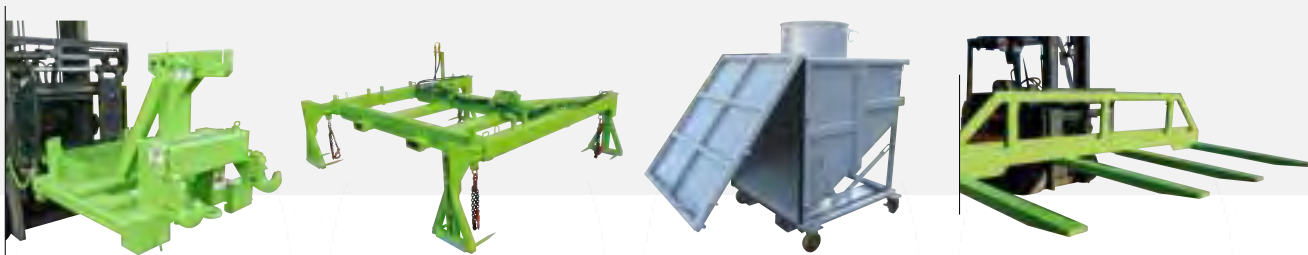

RESEARCH AND DEVELOPMENT

A five-strong team in our study office is continually working to improve our products, by always looking out for changes in your needs. Goubard thus endeavours every day to design and develop innovative technical responses that meet the specific demands of your area of work in every way.

Goubard cares about your experience as a user.

Can't find a standard model that suits you? Always ready to listen to you, we will provide you with made-to-measure manufactured items by developing optimised solutions for your each and every need.



OUR COMMITMENT

In a constructive and transparent relationship with its clients, Goubard will accompany you on a daily basis, in a spirit of long-term partnership based on fundamental values and assets such as :

- High-quality work
- Desire for client satisfaction
- A sense of innovation
- Human values
- Flexibility of adaptation
- Ongoing client assistance

THE TEST A UNIQUELY GOUBARD OFFER

To ensure that you are sure of your choice, Goubard offers you a chance to test before you commit.

95% of clients who test our products later buy them!

To find out about test methods and test an item of Goubard equipment, call :

+33 2 41 76 36 52



www.goubard.fr

Go on line to find all our products and options, more photos, and demonstration videos... All the information needed for making the right choice!



MEN AND WOMEN BY YOUR SIDE

Z.A. de Suzerolle nord
CS 80035
49140 Seiches-sur-le-Loir, France

T. +33 (0)2 41 76 36 52
F. +33 (0)2 41 76 63 33
export@goubard.fr
www.goubard.fr

**Your contacts are always ready
to listen to you by phone,
Monday to Friday.**



G Goubard
SEICHES-SUR-LE-LOIR

A TEAM AT THE HEART OF YOUR PROJECTS



Depending on where you are located, contact directly

EXPORTS

Martine FAUQUEREAU

RESEARCH & DEVELOPMENT, MADE TO MEASURE PRODUCTS

Jérémie BOURDILLON
Technical Manager

BUSINESS SECTOR

Dépt. EVEN-NUMBERED*

Martine FAUQUEREAU, Sector Manager
Amélie ZAMPARO, Business Manager

Dépt. IODD-NUMBERED*

Nathalie CHAUVELLIER, Sector Manager
Sandrine JUMEAU, Business Manager

* Département No

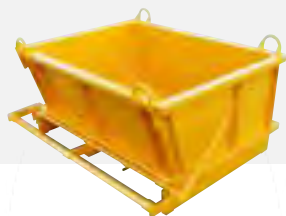

OUR SOLUTIONS



SOLUTIONS WITH PEOPLE IN MIND...

The safety of the operative and their working conditions have always been at the core of the design of our products.

Several innovations and patents have strengthened active and passive safety :

- Automatic unlocking of tilting by switch
- Fork locking
- Slide limiter
- Safety latch

All our products are compliant with the health and safety requirements of European Directive 2006/42/EC of 17 May 2006.



...AND THE ENVIRONMENT

Fully involved in your environmental procedures, **through our products, we help optimize the collection and sorting of waste in your company.**

With a genuine understanding of the realities of your business, we integrate your industrial processes and the regulatory constraints of your equipment to provide you with effective and sustainable solutions, while reconciling cost savings, productivity and technical expertise.



CONSTANT INNOVATION

Our technical teams design and develop new products to anticipate the expectations of the various markets and standards. They are highly committed to research and development in order to design and manufacture solutions that you can trust. With our historical and local know-how, we are cultivating the « Made in France » mentality.



CUSTOMISED SOLUTIONS FOR ALL REQUIREMENTS

Build the product that best meets your requirements in complete freedom :

- Dozens of options adapted to all requirements
- Painted, galvanized or stainless steel finish
- Choice of colour
- Option of special tailor-made products

For information on all the details and terms and conditions for made-to-measure ordering, refer to page 107 of the catalogue.

SOLUTIONS FOR ALL HANDLING OPERATIONS

Our products are equipped with various type of grips depending on your handling equipment :

- Front forklift fork grips, with rotating head, stacker
- Crane / Spreader / Slings
- Clamp Truck
- Other grippers : grappling hook / telescopic...



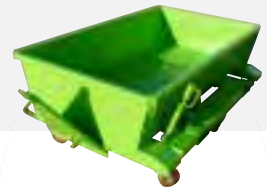

PRACTICAL GUIDE

UNDERSTANDING OUR TECHNICAL DIAGRAMS

Glossary :

- A : overall depth
- B : interior depth
- C : interior depth
- I : interior width
- D : overall height
- D¹ : interior height
- E : maximum loading height
- K : overall height (when emptying)
- F : fork sleeves spacing

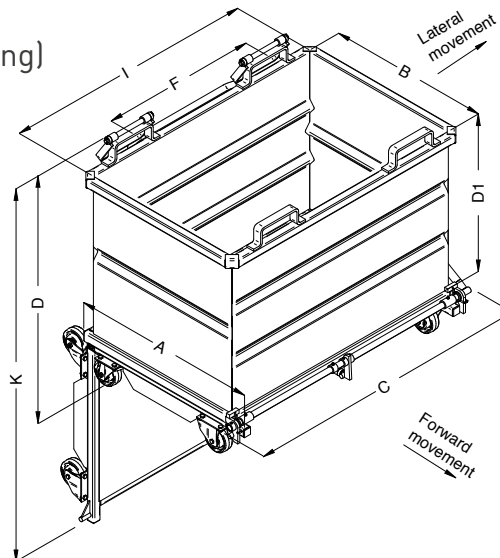
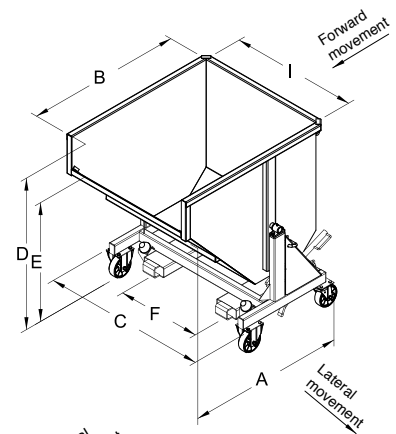

A man with a beard and glasses, wearing a hard hat and a work jacket, is inspecting a large, complex metal structure, likely a hopper or conveyor system. The structure is made of dark metal beams and panels. The background shows an outdoor setting with trees and a building. The entire image has a dark, reddish-purple tint.

HOPPERS

HOPPERS

FC/FD	Helmet hopper	50
FG	Guillotine hopper	52
FT	Hopper drop-bottom	53
TB-F	Hopper for big-bags on feet	54
TB-L	Filling hopper and big-bag lift	55
TSS	Tailor-made special hoppers	56



HELMET HOPPER

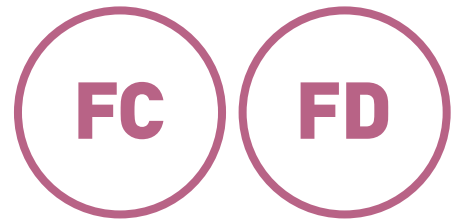

Central emptying by trap with helmet.
Suitable for all types of non-cohesive material, from powder to pebbles.
Regulated overflow.



1 basic capacity of 585 litres
without extension

Manual opening
using dual level

Aperture dimensions
300 x 240 mm

Version with
or without wheels

FC Type

- 2 mm folded sheet metal container
- Load capacity : 1200 kg

FD Type

- 3 mm folded sheet metal container
- Load capacity : 2000 kg

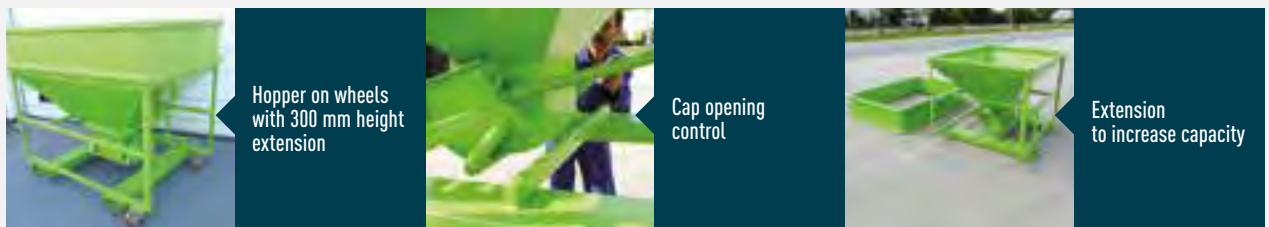

CHARACTERISTICS

- 1 basic capacity of 585 litres and 2 adaptable extension frames increasing capacity to 1085 or 1585 litres
- Controlled emptying flow, return spring on the helmet
- Helmet hinges mounted on bearings
- Fork sleeves aperture : 170 x 70 mm. Spacing (F) : 850 mm-modifiable on request
- Pedestal mounted models with pallet truck access points - Stackable
- Castor mounted models have 2 fixed and 2 pivoting castors Ø125 alu/polyurethane on FC hopper and Ø160 cast iron/polyurethane on FD hopper with handrail, lateral motion
- For customised production, please contact us

	Capacity litres	With	A	B	C	I	D	E	Weight kg	Painted ref.
FC Model : hopper thickness 2mm										
Hopper load	585	-	1200	1120	1580	1500	1050	-	150	FCP05000
	1200 kg	castors	1200	1120	1670	1500	1110	-	160	FCP05121
Extension	for 1085 L	-	1225	1120	1605	1500	-	300	40	REP20000
	for 1585 L	-	1225	1120	1605	1500	-	600	65	REP25000
FD Model : hopper thickness 3mm										
Hopper load	585	-	1200	1120	1580	1500	1050	-	205	FDP05000
	2000 kg	castors	1200	1120	1670	1500	1160	-	225	FDP05162
Extension	for 1085 L	-	1225	1120	1605	1500	-	300	60	REP30000
	for 1585 L	-	1225	1120	1605	1500	-	600	100	REP35000

Dimensions in mm for basic model (for guidance only).

OPTIONS AND FUNCTIONS OF USE

FD with optional special lid



stackable feet

FOR CUSTOMISED PRODUCTION

See Page 56

*Customised
with caster-
mounted frame*



*FD with extension and
Big-Bag handle hooks*



Helmet opening by lever

585 L stainless steel model

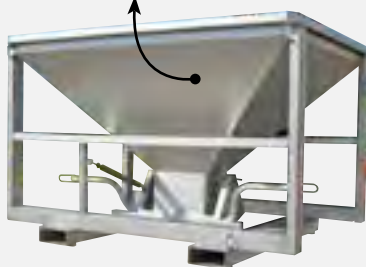

Optional reduced aperture

*High-capacity custom-made
hopper in stainless steel*



GUILLOTINE HOPPER

FG

For transport and distribution of aggregates.
Central emptying through gate.
Complete or partial dumping.

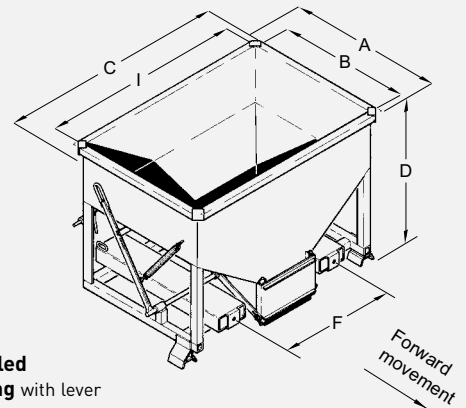

Version with or without wheels



Optional front lever



Castor-mounted
500 L model

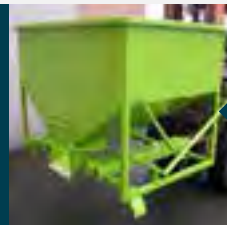

Lever locked,
gate open

CHARACTERISTICS

- Capacity from 500 to 1400 litres
- Bin : 3 mm sheet metal
- Lever locks in position for complete emptying
- Fixed-foot models are stackable
- Safety chain included
- Castor-mounted models have 2 fixed + 2 pivoting Ø125 mm alu/polyurethane castors and a handrail - forward movement
- For customised products, please contact us
- Available options include : gate blocking device (pre-set notches) and a waterproof guillotine

Capacity litres	Load kg	Castors Ø	A	B	C	I	D	F	Weight kg	Painted ref.
500	1000	-	920	800	1340	1200	970	700	160	FGP05000
500	1000	125	980	800	1340	1200	1030	700	170	FGP05121
750	1300	-	920	800	1340	1200	1230	700	185	FGP07000
750	1200	125	980	800	1340	1200	1290	700	195	FGP07121
1000	1700	-	1130	1000	1650	1500	1220	700	210	FGP10000
1000	1200	125	1180	1000	1650	1500	1280	700	220	FGP10121
1400	2200	-	1130	1000	1650	1500	1485	700	255	FGP14000
1400	1200	125	1180	1000	1650	1500	1545	700	265	FGP14121

Dimensions in mm for basic model (for guidance only).

DROP-BOTTOM HOPPER



Channeled emptying through base.
Fork bottom lift.

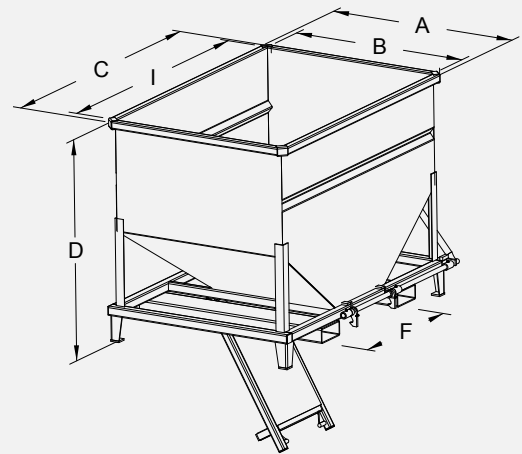

CHARACTERISTICS

- Capacities from 750 to 1500 litres
- Empties via lower hinged trap-door.
Aperture :
 - 480 x 530 mm (750 and 1000 L models)
 - 480 x 730 mm (1250 and 1500 L models)
- Lever for manual opening, remote control possible
- Fork sleeves aperture : 170 x 70 mm.
Spacing (F) : 750 mm
- Safety chain included
- For customised products, please contact us

Capacity litres	Load kg	A	B	C	I	D	F	Weight kg	Painted ref.
750	1500	950	800	1350	1200	1095	750	195	FTP07000
1000	2000	950	800	1350	1200	1355	750	220	FTP10000
1250	2250	1150	1000	1645	1500	1190	750	250	FTP12000
1500	2500	1150	1000	1645	1500	1355	750	270	FTP15000

Dimensions in mm for basic model (for guidance only).

HOPPER FOR BIG-BAG ON FEET



Use with loading bucket to fill big-bags quickly.
Clean work space.



Choose your hopper according to your loading bucket dimensions

Adjustable legs height in option

Pre-drilled plates secure hopper to the ground (recommended)

4 quick release hooks for keeping Big-Bag

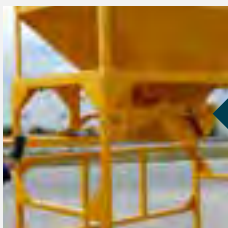
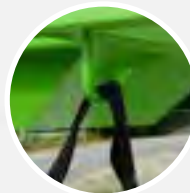
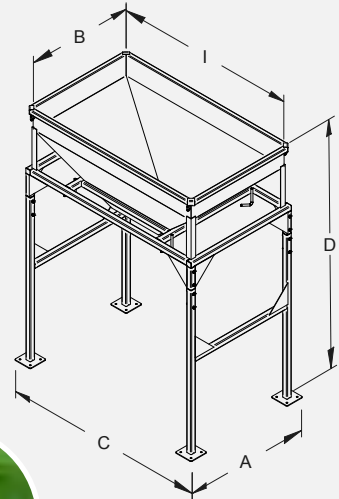

Optional dual helmet with reinforced frame

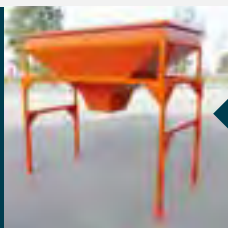

TB with optional reduced opening



Custom made product reinforced with adjustable legs and special hooks

CHARACTERISTICS

- Tubular base reinforced with gusset plates
- Hopper : 3 mm sheet metal with reinforcing ribs
- Chute aperture : 500 x 500 mm
- Clearance below hooks : 1650 mm
- **Tip** : place a pallet under big-bag facilitating its removal, and never have burden on hooks
- Available options include : double flat helmet or flowregulating sliding gate, according to load and product type (contact us)
- Other sizes available on request

Capacity litres	Forward		Lateral		D	Hook spacing	Weight kg	Painted ref.
	Interior (I)	Overall (C)	Interior (B)	Overall (A)				
830	1700	1900	1000	1200	2355	995 x 914	221	TBP08000
830	2100	2300	1000	1200	2355	995 x 914	243	TBP10000
1220	2500	2700	1000	1200	2600	845 x 905	287	TBP11000
1460	3000	3200	1000	1200	2630	910 x 900	317	TBP13000

Dimensions in mm for basic model (for guidance only).

FILLING HOPPER AND BIG-BAG LIFT

TB-L



**Filling and handling of the big-bag.
3 widths.
Permissible load 2 tonnes.
Approved by body of control.**

**Painted or
galvanized
version**

Choice of hopper
depending on the width
of the loading bucket

Mobile hopper to fit
on forklift truck forks

4 hooks
supporting the
suspended load



4 big-bag handles
for rapid unhooking

**Automatic locking
on forks enabling
the bag to be
unhooked going
backwards**

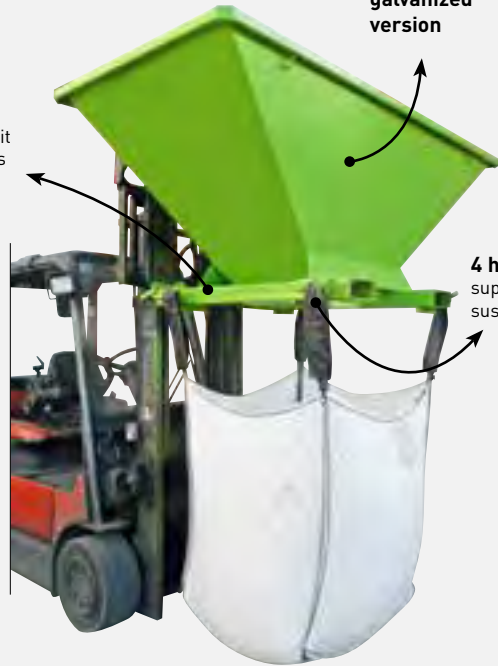

⚠ ATTENTION : Prior to use, accessory + forklift acceptance procedures must be carried out by your authorised inspection body.



**Steep edges
improving the flow
of materials**



**Automatic locking
by stirrups when
lifting**

CHARACTERISTICS

- 3 mm steel panel hopper with reinforcement pleats
- 500 x 500 mm outlet channel
- Forks gripped in 5 mm thick sleeves, 170 x 55 int. passage, 680 mm between forks
- Distance between hooks 900 x 1041 mm

Capacity litres	A	B	C	I	D	F	Weight kg	Painted ref.
830	1280	1000	1780	1700	870	680	170	TBP28000
830	1280	1000	2180	2100	910	680	176	TBP30000
1460	1280	1000	3080	3000	1140	680	233	TBP33000

Dimensions in mm for basic model (for guidance only).

TAILOR-MADE SPECIAL HOPPERS



Tell us your technical requirements and we will build your hoppers to measure !

Opening control by manual lever or handle.
Controlled and channeled emptying.
Painted, galvanized or stainless steel finish.

Version on base or on wheels.
Various chutes.



Sealed sliding hatch

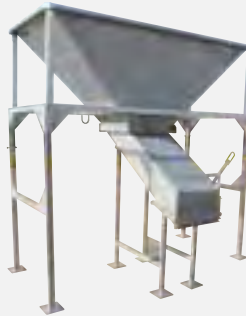

Sliding hatch and special downspout



Hopper with breathing pipes



Diaphragm valve

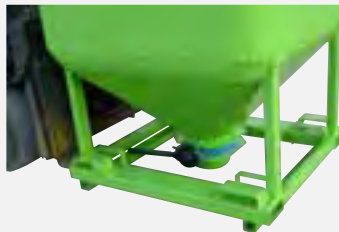

Lever butterfly valve



Handwheel butterfly valve



Offset helmet hopper



Dual-helmet hatch



Sliding hatch on external rollers

TAILOR-MADE SPECIAL HOPPERS



Spherical ball valve



Articulated rotating hatch



Pinch valve



**Reinforced
by anti-punching flanges**



Sealed sliding hatch



Crane grip helmet hopper

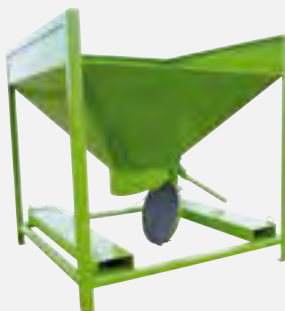

**Round chute, sealed
by eccentric lever**



**Basic sliding hatch
for light products**



**Flow adjustment sliding hatch with
reduction gearing and angle gearing**

A close-up, grayscale photograph of a metal hinge mechanism, likely from a door or a heavy-duty cabinet. The hinge is mounted on a metal surface, and the door or panel is partially open, revealing the internal structure and the hinge's pivot points. The lighting is dramatic, highlighting the metallic textures and the mechanical details of the hinge.

OPTIONS

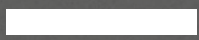

OPTIONS

FINISH/BLOCKING/RELEASE

Finishing choice :

Stainless steel, galvanized version or customised paintwork



Blocking on forks (BFP)



Automatic release (DAP) :

by pressure, by contact, by drawbar



OPTIONS

LIDS

Sliding lid (CLP)
plastic strips or metal version



Dead-light
(OPP)



Hinged two parts lid
(COP)



Folding lid
on BR



Custom removable lid
(COS)

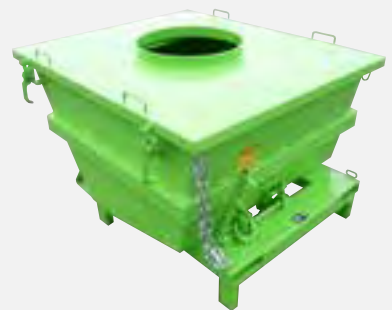

Fixed lid
with virole (CVP)



Articulated lid
with 1 ferrule (VIP)



Special cover
Lockable, opening with gas compass



OPTIONS

SPECIAL SLEEVES

For stacker



Clamps hold on tipping bin



Clamps hold on drop bottom skip



3 points for tractor



Fork sleeves on 3 sides (PTP)



Opening limiter (LOP)



Guide flanges (FLP)



Locked bin tilted (BBP)



OPTIONS OTHERS

Grille and drain tap
(GRP)



Leakproof door
with foam seal (FEP)



Adhesive letters
(MAP)

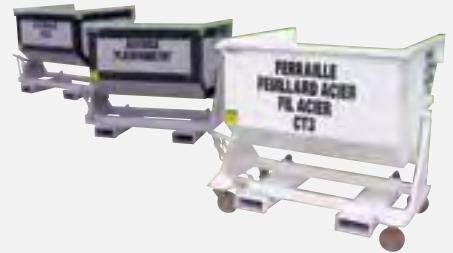

Trailer drawbar
(TRP10000)

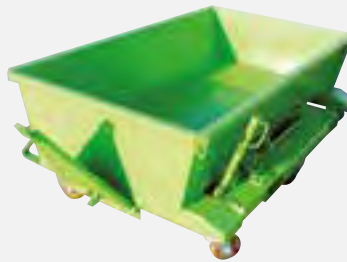

Deceleration cylinder
for end of tipping process (VRP)



Hydraulic tipping
1 or 2 cylinders (BHP)



OPTIONS OTHERS

4 lifting lugs
(BAP)



Security by screw



Special leakproof inspection window
(in steel or plexiglass on request)



Tarpaulin or netting
(FBP)



Cross fork sleeves
on FAP/CAP models (FVP)



Lid
with aluminum roller shutter



Customized leak-proof lid
with ferrule on tipping skip



**OTHER OPTIONS
CONSULT US**

CUSTOM MADE PRODUCTS



CUSTOM MADE PRODUCTS



IMAGINE, INNOVATE, CREATE, GAIN YOUR TRUST...

With **recognized know-how**, an ability to listen and professional expertise, we add to our wide range of standard products with tailor-made products to become your ideal partner and offer you :

- **Unique expertise in the analysis of your requirements**
- **Personalised advice**
- **Solutions to each of your issues**
- **A proactive service**
- **Guaranteed quality, reliability and safety**

Our design office works every day to invent and develop products to provide you with solutions adapted to your requirements and the regulations (EC).

The contract manager is your contact with all the company's services. They guide you through the development of your project and answer all of your questions.

Talk to us and benefit from our experience.

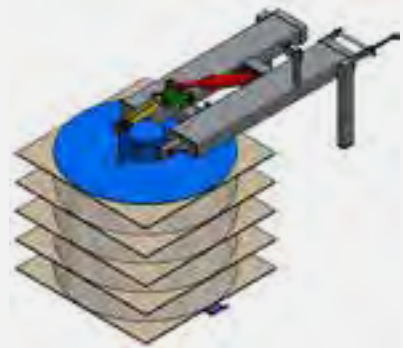

A tailor-made product designed to meet all your requirements !

CUSTOM MADE PRODUCTS

Multi-compartment skip
Tilting or opening bottom



Wire mesh version



Adaptation
with hinged tipping



Bin with opercule
or special glass hatch



CUSTOM MADE PRODUCTS

Adaptation fork sleeves

For lift truck with clamps



Hydraulic nipper

nipper



Tilting frame

For making wood faggots



BR-C skip

with command of opening lid with pedal



Special jib stacker grip

for storage platform



Hydraulic tilting

specific



Autonomous tilting device

12 volts - for plastic bin

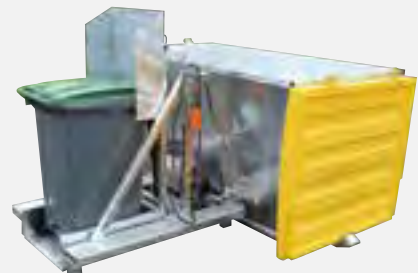

CUSTOM MADE PRODUCTS

Mobile ramp
special QL



Mounting on specific wheels
For use with or without



Truck
for fire equipment



Truck
Handling



Open-bottom skip
with special lid



CUSTOM MADE PRODUCTS

Special skip
for telescopic truck

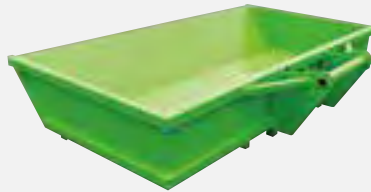

Grab point



Coupling with drawbar



Open sides
for long products

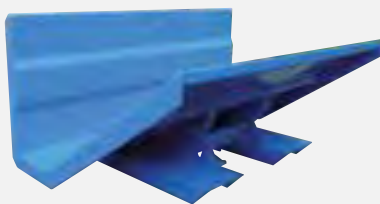
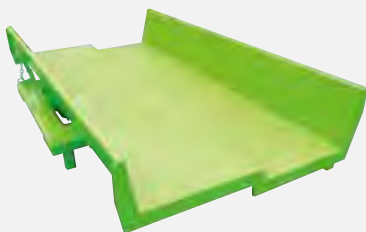

Skip
with double-axle steering



CUSTOM MADE PRODUCTS

Reinforced skips

Steelworks / foundry / aspiration



Hydraulic tilting

on tipping skip

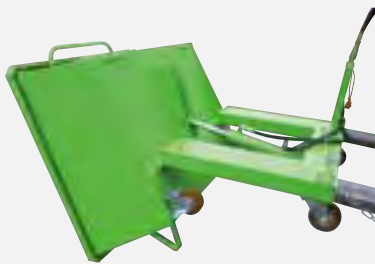

Skip

for machine environment

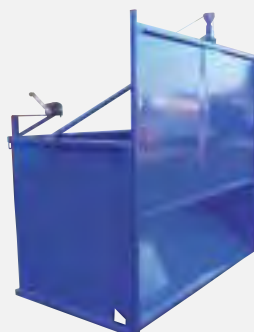
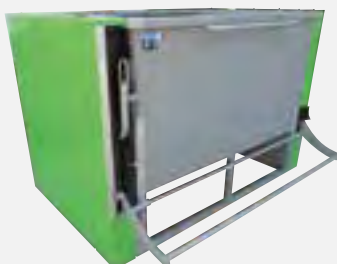
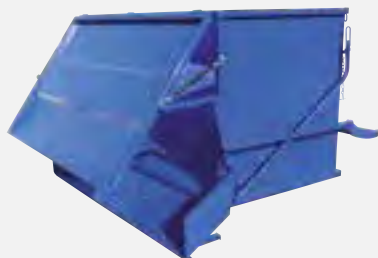

Sloped bottom skip

special

TELL US WHAT YOU NEED AND WE'LL MAKE THE SKIP TO FIT!



FOR A FREE ESTIMATE, PLEASE FILL IN THE FORM BELOW AND RETURN IT TO US.

Company :

Contact/Name :

Address :

Post code : City :

Tel. : Fax : E-mail :

Sphere of activity :

YOUR TECHNICAL REQUIREMENTS

Type of products handled :

Estimated load :

FINISH : Painted galvanized Stainless steel Food-safe paint Leak proof bin

TYPE : Pedestal-mounted model Castor-mounted model 2 fixed + 2 pivoting 4 pivoting
Forward movement Lateral movement

For use with : Forklift Stacker

Tipping system : Manual Hydraulic

QUANTITY :

DESIRED OPTIONS AND/OR COMMENTS :

DIMENSIONS REQUIRED

A (overall depth) :

or

B (interior depth) :

C (overall width) :

or

I (interior width)) :

D (overall height) :

F (fork sleeves spacing) :

Dimensions of your forks : X

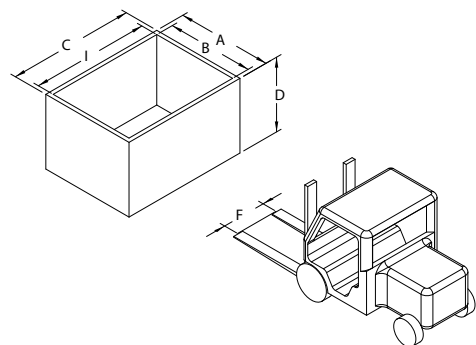

INFORMATION REQUIRED FOR A SUITABLE SOLUTION

INFORMATION ON YOUR NEED

- Choice of the equipment : skip, shovel, hopper, accessorie...
- Nature of products / handled waste
- Density or estimated load
- Capacity (in liters), desired dimensions
- Version on base / on wheels
- Finish : painted / galva / stainless steel...
- Quantity
- Options
- Other constraints to respect



INFORMATION ON THE HANDLING

- Prehension by : forklift truck, stacking truck, crane....
- Place of emptying
- Diverse constraints
- Section and spacing forks
- Load, lifting height of the forklitf truck

Well expressed choices facilitate selection !

ADD COLOUR YOUR WORKING ENVIRONMENT !

Our products are coated with a green polyurethane paint. As standard, we also offer the range of RAL colours below. Other RAL colours are available as an option so that our products can integrate seamlessly into your environment.



GREEN
Standard



YELLOW RAL
1003



YELLOW RAL
1028



ORANGE RAL
2004



RED RAL
3000



BLUE RAL
5015



GREEN RAL
6029



GREY RAL
7036



BROWN RAL
8004



BLACK RAL
9005



WHITE RAL
9010





Goubard

Z.A. de Suzerolle nord

CS 80035

49140 Seiches-sur-le-Loir, France

T. +33 (0)2 41 76 36 52

F. +33 (0)2 41 76 63 33

export@goubard.fr

www.goubard.fr